

# Guide to automatic gate safety



Be ahead

# Contents

<b>1.</b>	Introduction and scope of these safety guidelines . . . . .	2
<b>2.</b>	Explanation of common automatic gate hazard types . . . . .	3
<b>3.</b>	Specific hazards and control measures for automatic gates . . . . .	4
<b>3.1</b>	Automatic sliding gates. . . . .	4
<b>3.2</b>	Automatic swing gates . . . . .	5
<b>3.3</b>	Control measures explained. . . . .	6
<b>3.4</b>	Increased risk . . . . .	7
<b>4.</b>	General safety recommendations . . . . .	7
<b>5.</b>	Training . . . . .	7

## Introduction and scope of these safety guidelines

The purpose of these safety guidelines is to assist any people and companies that design, manufacture, install, maintain, and inspect automatic gates. Automatic gates can injure and kill people, but, as of today, no safety standards exist in Australia and New Zealand to regulate the installation of automatic gates. With these safety guidelines, BFT Australia & New Zealand wish to bring more awareness on the ri-

sks posed by automatic gates and what preventive actions can be taken to reduce the safety risks to their users. In fact, our mission is to strengthen trade professionals' feelings of assurance, confidence, and empowerment when providing access solutions. We sincerely hope you find these safety guidelines useful. If you have any feedback or questions, please contact us on [info.australia@bft-automation.com](mailto:info.australia@bft-automation.com)

## Disclaimer

These guidelines are intended as a guide only. They are not directions and Bft Automation Australia Pty Ltd and BFT Automation New Zealand Limited shall not be liable for any injury, death, or loss or damage arising from the following of, or failure or inability to follow these safety guidelines or from any action or decision taken as a result of following these guidelines. The information included in these safety guidelines comprise BFT Automation Australia Pty Ltd and BFT Automation New Zealand Limited's views only. They do not constitute legal or other professional advice, or directions for use.

## 2 Explanation of common automatic gate hazard types

Several types of automatic gate hazards are possible. The most common are crushing, shearing, impact, drawing-in, cutting, hooking, and imprisonment. The next paragraphs will discuss these automatic gate hazard types in turn. The next section will discuss safety control measures.



Figure 2.2 Shearing

### Shearing

Shear hazards can occur when an automatic gate causes a guillotine or scissoring effect (see Figure 2.2). Shear hazards can result in broken limbs.



Figure 2.1 Crushing

### Crushing

Crush hazards are perhaps the most dangerous type of automatic gate hazards since they can lead to serious injury or death (see Figure 2.1). They usually are caused when gaps between gates and posts or walls are larger than 500mm. The most effective way to avoiding crushing

is by controlling and reducing gaps as much as possible. Other control measures will be discussed in section 3.



Figure 2.3 Impact

### Impact

Impact hazards can occur when a moving leaf or gate makes contact with a person outside of the crushing zone (see Figure 2.3).

Impact hazards can cause damage to goods and injury to persons. This hazard can also cause a person to fall and be exposed to other hazards.



Figure 2.4 Trapping, dragging, or drawing-in

### Trapping, dragging, or drawing-in

Trapping, dragging, or drawing-in hazards can occur when a moving gate pulls a body part into a gap (see Figure 2.4). These hazards often exist in the same areas as shear hazards and can cause injury more often than shearing. Injuries include broken limbs, bruising, and death.



Figure 2.5 Cutting

### Cutting

Cut hazards can be caused by moving gates with sharp protrusions (see Figure 2.5). One way to avoiding cut hazards is the removal of sharp and protruding objects or edges from the moving gate.



Figure 2.6 Hooking

### Hooking

Hook hazards can occur when a person's clothes get caught on a moving gate (see Figure 2.6). Like cut hazards, one way to avoiding hooking hazards is by removing sharp and protruding objects or edges from the moving gate.



Figure 2.7 Imprisonment

### Imprisonment

Imprisonment hazards can occur when a moving leaf or gate prevents a person from escaping. The main way to avoid imprisonment hazards is by educating end-users on how to use the manual release mechanism.

Now that a list of the most common types of automatic gate hazards has been provided, this section will illustrate the automatic gate areas where injury could potentially be caused, and the control measures needed to prevent such hazards. The first part of this section will focus on sliding gates while the second part will deal with swing gates.

### 3.1 Automatic sliding gates

The areas of an automatic cantilever sliding gate where injury could potentially occur are displayed in Figure 3.1 below. See areas A to H.

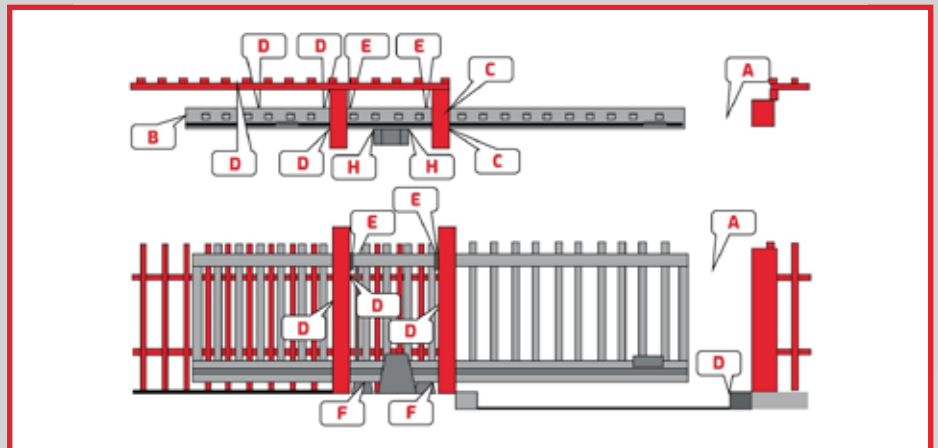

Figure 3.1 Elevation and plan view of an automatic cantilever sliding gate.

In addition, the areas of an automatic tracked sliding gate where injury could potentially occur are shown in Figure 3.2. See areas A, B, and H.

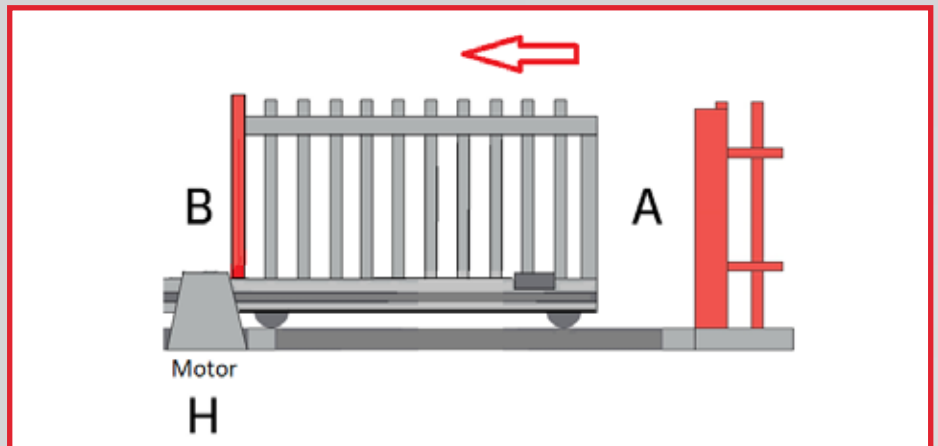

Figure 3.2 Plan view of a tracked sliding gate.

Now that the hazard areas of cantilever and tracked gates have been identified, the below paragraphs describe these hazard areas and the type of measure that should be put in place to control the risk from each hazard.

**A Main closing edge where crush and impact hazards are possible.**

Control measures include gate opener torque force limitation, safety beams, safety edges, laser scanners, and hold-to-run function and devices.

**B Main opening edge where crush and impact hazards are possible.**

Control measures include guarding, gaps reduction, gate opener torque force limitation, safety beams, safety edges, hold-to-run function and devices, and laser scanners.

**C Entrance portal support frame where shear, trap, drag, or draw-in hazards can occur.**

Control measures include gaps reduction, safety beams, safety edges, laser scanners, and hold-to-run function and devices.

**D Other support frames, leaf, or perimeter where shear, trap, drag, or draw-in hazards are possible. When a sliding gate with vertical bars, opens alongside a fixed panel with vertical bars, this causes many dangerous areas of potential crushing.**

Control measures include guarding, safety beams, safety edges, laser scanners, and hold-to-run function and devices.

**E Upper guide or upper rollers where trap, drag, or draw-in hazards can happen.**

Control measures include guarding, laser scanners, and hold-to-run function and devices.

**F Lower cantilever rollers where trap, drag, or draw-in hazards are possible.**

Control measures include guarding exposed rollers.

**G Lower tracked gates wheels where trap, drag, or draw-in hazards can occur.**

Control measures include guarding to within 8mm of ground.

**H Gate opener pinion where trap, drag, or draw-in hazards can happen.**

The main control measure is about guarding the gate opener.

### 3.2 Automatic swing gates

Now that the hazard areas of swing gates have been identified, the below paragraphs describe these hazard areas and the type of measure that should be put in place to control the risk from each hazard.

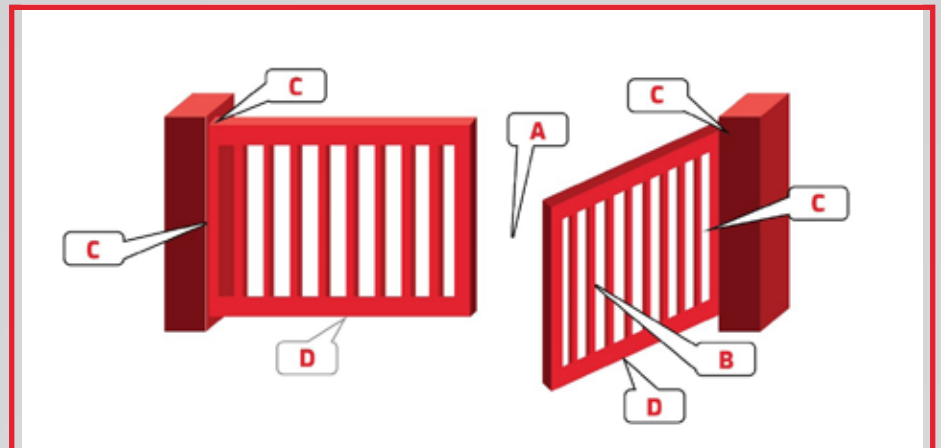

Figure 3.3 Plan view of a swing gate.

**A Main closing edge where crush and impact hazards are possible.**

Control measures include the use of safety beams together with gate opener torque force limitation or safety edges, laser scanners, and hold-to-run function and devices.

**B Opening edge where crush and impact hazard can occur.**

Control measures include gaps reduction (see Figure 3.4), gate opener torque force limitation, safety beams, safety edges, laser scanners, and hold-to-run function and devices.

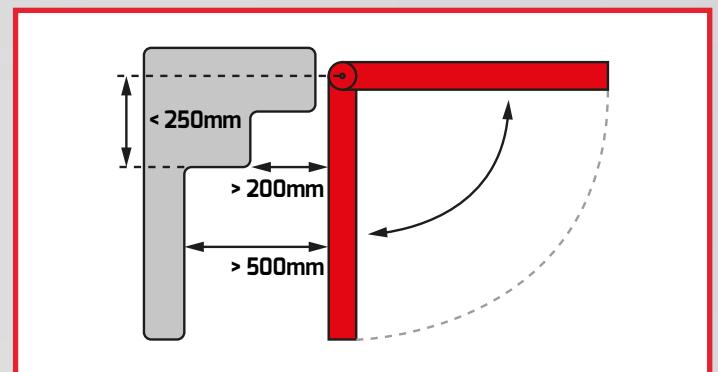

Figure 3.4 Gap reduction to reduce crushing hazard.

**C Hinge areas where crush, shear, and trap, drag, or draw-in hazards are possible.**

Control measures include the use of safe design hinges (see Figure 3.5), guarding, safety beams, safety edges, laser scanners, and hold-to-run function and devices.

**D Lower edge where shear and crush hazards can occur.**

Control measures include gate opener torque force limitation together with gaps reduction (see Figure 3.6), safety beams, safety edges, laser scanners, and hold-to-run function and devices.

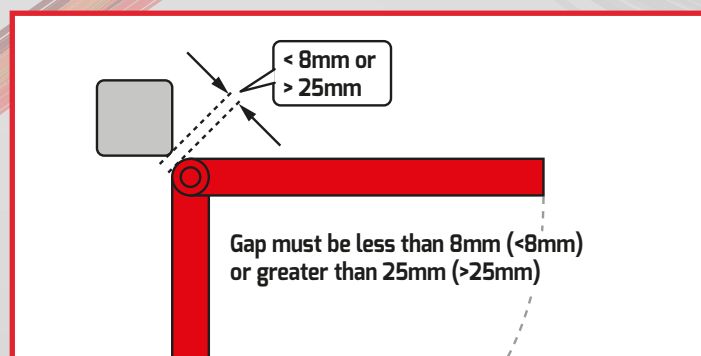

Figure 3.5 Safe design hinge.

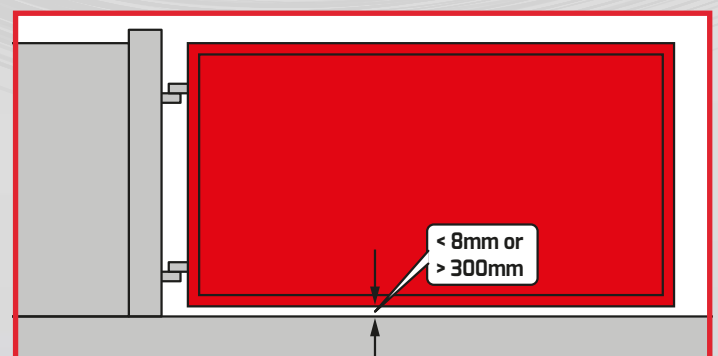

Figure 3.6 Gap reduction to control shear and crush hazards.

### 3.3 Control measures explained

This section provides more explanation of some of the control measures mentioned in the previous section:

#### Gate opener torque force limitation

Torque force limitation is usually provided by the automatic gate opener. In some cases, such as in all 24volt BFT gate openers and operators featured with a built-in encoder, the torque force limitation function will cause the gate to reverse when an obstacle is sensed. Some gate openers, such as all BFT operators, feature an auto-set function that allows the product to learn the most appropriate torque force necessary to move each specific gate. In addition, most BFT gate openers and control boards sold in Australia and New Zealand include the exclusive d-track dynamic patch tracking system unique to BFT. As opposite to conventional gate openers and control boards that apply constant torque force in any gate position, the d-track featured BFT products learn to adjust the torque force output to different requirements. For example, during

gate opener torque force limitation, safety beams, safety edges, laser scanners, and hold-to-run function and devices.

the opening phase, d-track products will output a higher level of torque force to win the initial inertia and a lower level of torque force after the opening phase when the inertia has been won and less torque is required to continue moving the gate.



The sensitivity of d-track featured BFT products is much higher than most conventional products, making them some of the safest in the market. Please contact us for further information.

#### Safety beams

Safety beams, also called photocells, are a pair of infrared sensors that are placed on either side of a driveway. If the infrared beam is broken while the gate opener is operating, the safety beams send a signal to the control board to stop and reverse the direction of the gate (see Figure 3.7). There are several types of safety beams, including hard-wired, wireless, and reflective. Please contact us for further information on BFT's range of photobeams.

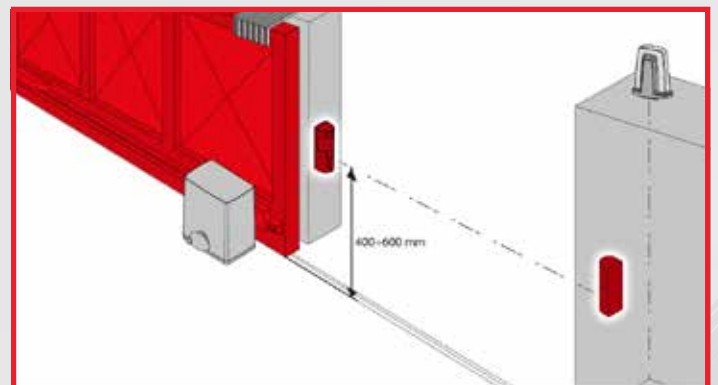

Figure 3.7 Safety beams installed on an automatic sliding gate.

#### Safety edges

Safety edges are sensitive rubber switching strips or profiles that send a message to the control board to reverse the movement of the gate when an obstacle is detected (see Figure 3.8). There are many different types of safety edges. Some safety edges are mechanical while others work with infrared devices. Please contact us for further information about BFT's range of safety edges.



Figure 3.8 Example of safety edges installed on a sliding gate.

### Laser scanners

Laser scanners place a curtain of radar around a danger area. If the curtain of radar is breached while the gate opener is functioning, the gate will stop and reverse its direction. See figure 3.9.

### Hold-to-run function and devices

Hold-to-run is a function granted by most gate openers. It allows the gate opener to operate only when a person is consciously placing continuous pressure on a push button, key switch, or any other controllers, from a safe area.

### Warning signage

It is advisable, especially in commercial and public spaces, that any automatic gates be fitted with some type of clear warning signs as per Figure 3.10 below.

### 3.4 Increased risk

The safety risks discussed so far in relation to automatic gates can increase in certain situations that require additional care. These situations include when the automatic gate is used by children, disabled, or elderly people, when the automatic gate is subject to a high frequency of use, and when it is not possible to train or supervise the automatic gate users. In these circumstances of increased risk, a larger number of control measures is required.



Figure 3.9 Example of a laser scanner installer on an industrial door.



Figure 3.10 Example of warning signs

## 4 General safety recommendations

This section provides some general safety recommendations that automatic gate installers should give to the end-user.

Firstly, the automatic gate must be kept in a condition that is safe to use through regular and adequate maintenance. Maintenance should, at least, include a test of the automatic gate safety features and, possibly, a test of the opening and closing forces to ensure adequacy.

In addition, the installer should demonstrate to the end-user how to manual release the automatic gate in an emergency. Releasing the gate should be easy

and quick to do. Moreover, the installer should also discuss the safety features of the automatic gate with the end-user, including any safety beams, safety edges, laser scanners, guards, and the torque force limitation features of the automatic gate opener. The installer should always educate and make mention to the end-user the high risks associated with children operating or playing in and around automatic gates. Furthermore, the end-user should be shown where and how to isolate the power to the gate. It is always recommended that this isolation switch be within 3 metres of the gate.

## 5 Training

Training is essential to learn the up-to-date information about the latest safety issues and control measures. BFT Australia & New Zealand offer a complimentary safety training course to any installers who wish to expand their knowledge in the automatic gate safety space. Please contact us if you are interested to learn more:

Telephone: 1300 729 344 Australia  
0800 288 642 New Zealand  
Email: [techsupport.australia@bft-automation.com](mailto:techsupport.australia@bft-automation.com)

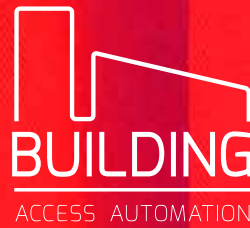

OUR CORE VALUES:  
GROWTH - SUPPORT - INNOVATION

**BFT AUTOMATION NSW**

Sydney · 29 Bentley Street  
Wetherill Park - NSW 2164  
info.australia@bft-automation.com  
T. 1300 729 344

**BFT AUTOMATION VIC**

Melbourne · 18/191-195 Greens Road  
Dandenong South · VIC 3175  
info.australia@bft-automation.com  
T. 1300 309 709

**BFT AUTOMATION QLD**

Brisbane · 21 / 214-224 Lahrs Road  
Ormeau QLD 4208  
info.australia@bft-automation.com  
T. 1300 655 710

**BFT AUTOMATION NEW ZEALAND**

224/a Bush Road · Albany  
Auckland, 0632  
info.newzealand@bft-automation.com  
T. +64 (0) 800 288 642

